

Design of a Seawater Desalination Device for Laboratory Scale Solar Still Systems with the Addition of PCM (Phase Change Material) as a Heat Storage Material

by Noor Iskandar Noor Iskandar

Submission date: 22-May-2023 10:55AM (UTC+0700)

Submission ID: 2098858930

File name: 012-0016_2022.pdf (1.04M)

Word count: 6411

Character count: 31126

Design of a Seawater Desalination Device for Laboratory Scale Solar Still Systems with the Addition of PCM (Phase Change Material) as a Heat Storage Material

NOOR ISKANDAR¹ DODDY IRAWAN^{2,*} EKO JULIANTO³ RAUDHATUL FADHILAH⁴

^{1,2,3}Department of Mechanical Engineering

⁴Department of Chemistry Education

Universitas Muhammadiyah Pontianak

Jalan Jendral Ahmad Yani No. 111, Pontianak

INDONESIA

Abstract: - Water is the most important element in life. Over time, the need for fresh and clean water becomes a problem that often occurs in coastal areas during the long dry season. To overcome the occurrence of water shortages, water purification technology is developed. Solar seawater desalination is one of the techniques for water purification by distillation, utilizing sunlight as the main energy source. In this study, the authors designed a tool using the Autodesk Inventor software that will then be used in real-world terms. In this study the desalination device was combined with heat storage material. Paraffin wax is used as a phase-change material (PCM) that functions to store and release heat. In this study, the tool was made with a single slope with an area of 1 m² and a slope angle of 25°. The test was carried out at 08.00 to 20.00, carried out for ± 1 week, data taken on a device with 2 treatments including will be taken without PCM and using PCM, for fresh water produced depending on the intensity of the existing sun. From the tests that have been carried out for fresh water production on tools that were treated using PCM as much as 1052 ml and for fresh water production on tools with treatment without PCM as much as 904 ml, so it can be concluded that for fresh water production on tools added PCM produces water bargain more than the tools without PCM.

Keywords: Solar Still System Desalination, PCM (Phase Change Material), seawater

Received: May 21, 2022. Revised: October 23, 2022. Accepted: November 19, 2022. Published: December 29, 2022.

1 Introduction

Water is one of the most important elements needed in our daily lives and in the environmental system[1]. Water is also the main element for agriculture, industry, power generation, and transportation[2]. As the population increases, the need for clean water also increases. The problem of a lack of clean water supply creates a big problem in dry areas [3] and is becoming an increasingly important issue. It is also considered one of the most urgent problems in many countries that have experienced water scarcity for a long time [4] and must be treated immediately[5]. Scarcity of fresh water and clean water is a problem that often threatens populations in many areas around the world, especially in coastal areas during the long dry season. Most of the earth's surface is covered by water [6]—almost 70% of the earth's surface—of which about 97% is salt water and 3% is fresh water found in polar ice, rivers, lakes, and water inside the earth, or what is called groundwater, which provides most of the needs of living things. With the current pace of industrial development, this does not rule out the possibility of threatening the availability of clean

water, since decent water quality is not always available in nature[7].

The many available natural resources can be utilized to obtain renewable energy sources. Renewable energy is known to be friendly to the environment, and its waste does not have the potential to damage the surrounding environment and is not dangerous[8]. Solar thermal energy is a renewable energy source that is widely available in both direct and indirect forms[9]. Solar desalination is considered one of the most appropriate solutions for producing clean water[10] to overcome the problem of water scarcity that threatens human life in various regions[11]. By utilizing solar energy to produce fresh water directly or indirectly, where heat energy from the sun is supplied to the desalination device[12], it is an environmentally friendly technology that contributes efficiently to the sustainable development of the country. The need for small-scale solar desalination units continues to increase, especially in dry areas where solar energy is abundant and fresh and clean water resources are limited[13]. It is estimated that in the future, solar stills (a desalination system that uses solar energy)

will be more popular and widely used. Even for the country of Saudi Arabia which is known as one of the largest producing countries of fossil fuels, but to power the desalination system they use solar energy[14]. Phase Change Material (PCM) as a latent heat energy storage has attracted the attention of researchers and engineers in various fields[15]. One of its applications is in the field of fresh water production. In this study, the author uses a desalination tool as a tool used to apply PCM, which is one of the most effective techniques to use in producing fresh water, with the addition of PCM as a heat energy storage, which prospectively is expected to be able to improve the performance of the tool[16].

2 Literature review

2.1. Water

Water, which has the chemical formula H_2O [17] is one of the most important elements for life on earth, all ecosystems depend on it, especially clean and fresh water. Clean water is water that is clear, odorless, and tasteless, so it is suitable for consumption. In addition to meeting the main needs of the body in the form of drinks and food, water is also very necessary for bathing, washing, and other household needs[18].

2.2. Solar energy

The sun is a renewable resource with abundant availability because it emits radiant energy. The amount of sunlight that radiates to the earth's surface is very large. Among them is Indonesia, which has an average solar radiation intensity of 880 W/m^2 [19]. The intensity of solar radiation is the strength of the radiation emitted by the sun in a certain direction. If a comparison is made, the amount of solar radiation energy is greater than that of natural gas, coal, oil, and other non-renewable natural resources[8].

2.3. Desalination

Desalination is one of the technologies used in the distillation process, where the energy used is sunlight, which is used directly to evaporate seawater or brackish water[20]. This process also aims to separate the salt content contained in seawater[21] or brackish water, which results in water having a low or no salt content so that it can be used for daily needs

such as drinking, industry, urban use, or household needs[22].

Desalination systems can be grouped into several types, one of which is:

2.3.1. Solar Still

A solar water distillation system, often referred to as a "solar still"[23], is one of the methods used in seawater distillation that utilizes solar energy as a source of heat energy in the process of heating water[24]. In its application, there are several factors that can affect the productivity of the tool, one of which is the secondary condensation cover material. The secondary cover (side cover on the tool) made of aluminum gives better results compared to ordinary glass because of its higher thermal conductivity[25]. Desalination is also an environmentally friendly tool that does not have the potential to damage the surrounding environment because it only uses solar energy as an energy source.

2.4. PCM (Phase Change Material)

PCM (phase change material) is a "latent" heat storage material and is a material that has the ability to absorb or release a certain amount of energy[26]. Energy transfer occurs when a material changes phase from solid to liquid or vice versa[16]. PCM is also one of the most appropriate heat storage techniques because of its high latent heat of transition, high energy density, and relatively low cost[27]. As for the classification, PCM is divided into several groups, including[28],[29]:

2.4.1. Organic phase bulk materials

Organic phase change materials include materials that repeatedly melt and freeze without phase separation or degradation due to their latent heat of fusion. As for organic phase-changing materials, namely paraffin and non-paraffin,

2.4.2. Inorganic phase change materials

Inorganic phase-change materials are classified as salts hydrate and metals.

2.4.3. Eutectic

A eutectic is a mixture of chemical compounds that freezes or melts at a lower temperature than the melting point of a mixture of the same compounds in different ratios, and also the melting point of each compound itself.

2.5.Heat Transfer

Judging from the Big Indonesian Dictionary (KBBI), what is meant by "heat" is heat energy that can be received and transmitted from one object to another. There are three types of heat transfer between substances: radiation, conduction, and convection. Heat transfer moves from a substance with a higher temperature to a lower temperature until it reaches an equilibrium state[30].

2.5.1.Heat

Heat is heat energy that can be delivered or received either by conduction, radiation, or convection. The amount of heat needed to lower or increase the temperature of an object is inseparable from the mass of the object (m), the type of object, or the specific heat of the object (c), and changes in temperature (ΔT). Then it can be formulated as follows:

$$Q = m \times c \times (T^2 - T^1) \quad (1)$$

Where:

Q = heat required (J)

m = object mass (kg)

c = specific heat ($\frac{J}{kg}$)

ΔT = temperature change ($^{\circ}C$)

2.5.2.Radiant Heat Transfer

Radiation heat transfer is heat transfer that occurs due to the emission of electromagnetic waves or without an intermediary[31]. Radiation heat transfer can occur without any intermediate object to be traversed[32], for example, sunlight shining on the earth, and this heat transfer can also occur in a vacuum. The concept of convectional heat transfer is based on the Stefan-Boltzman law. The Stefan-Boltzman law is expressed by:

$$Q = \sigma A(T_1^4 - T_2^4) \quad (2)$$

Where:

T = absolute temperature of the object, K($^{\circ}C$)

A = surface area, $m^2(ft^2)$

Q = convection heat transfer rate, watts (Btu/h)

σ = Stefan-boltzman constant. $5.669 \times 10^{-8} W/m^2.K^4$ ($0.1713 \times 10^{-8} Btu/h.ft^2.^{\circ}R^4$)

2.5.3.Conduction Heat Transfer

Conduction heat transfer is the process of transferring heat from an object with a high temperature to an object with a lower temperature by transferring heat through a solid or solid conducting medium[8]. For example, when heating the tip of a spoon, the heat will also flow to the base of the spoon. The basic equation of the concept of conduction heat transfer has the basic equation of Fourier's law. Fourier's law is expressed by:

$$Q = -k.A.\left(\frac{dT}{dx}\right) \quad (3)$$

Where :

k =thermal conductivity, $W/m.^{\circ}C$ (Btu/h.ft. $^{\circ}F$)(proportionality constant)

A =Cross-sectional area perpendicular to the direction of heat flow (m^2)

dT/dx =Temperature gradient in the direction of heat flow ($^{\circ}C/m$)

2.5.4.Convection Heat Transfer

Convictional heat transfer is a heat transfer process in which a liquid or gas with a high temperature flows to a place with a lower temperature, or heat transfer that occurs between solid objects and fluids, for example, boiling water in a heated pan. Convictional heat transfer has a basic conceptual equation with Newton's laws. Newton's law is stated by:

$$q_c = h_c A(T_w - T_s) \quad (4)$$

or

$$\frac{q_c}{A} = h_c (T_w - T_s) \quad (5)$$

Where:

T = temperature, $^{\circ}C$ ($^{\circ}F$)

A = surface area, $m^2(ft^2)$

q_c = convection heat transfer rate, watts (Btu/h)

h_c = convection heat transfer coefficient, $W/m^2.^{\circ}C$ (Btu/h.ft $^2.^{\circ}F$) (proportional constant)

$\frac{q_c}{A}$ = heat transfer rate per unit area (heat flux) W/m^2 (Btu/h.ft 2)

To calculate the convection heat transfer coefficient, the following equation (6) can be used[33].

$$h_c = 0,884 \left\{ (T_w + T_{gi}) + \frac{[P_w - P_{gi}][T_w + 273,15]}{[268900 - P_w]} \right\}^{\frac{1}{3}} \quad (6)$$

Where P_w and P_{gi} can be calculate using equation (7) and (8).

$$P_w = \left(25,317 - \frac{5144}{T_w + 273} \right) \quad (7)$$

$$P_{gi} = \left(25,317 - \frac{5144}{T_{gi} + 273} \right) \quad (8)$$

2.6. Desalination Efficiency

The efficiency of the desalination device is the ratio of the heat energy required to evaporate salt water to the amount of solar radiation received by the device through the absorber plate in a certain time interval[34]. To calculate the efficiency of the desalination device, the following equation can be used[35].

$$\eta_d = \frac{m_k \times h_{fg}}{A_c \times I_T \times t} \times 100\% \quad (9)$$

Where:

M_k = total mass of condensate water (kg)

h_{fg} = latent heat of vaporization (kJ/kg)

A_c = absorber plate area (m²)

I_T = solar radiation intensity (W/m²)

t = long testing time (s)

3 Research methodology

3.1. Place and time

The design and manufacture of this desalination device were carried out in the laboratory of the Faculty of Engineering, Mechanical Engineering Study Program, Muhammadiyah University, Pontianak, Sui Ambawang Kuala, Kec. Ambawang River, Kubu Raya Regency, West Kalimantan, with a construction time of 4 weeks. Then this tool was installed for testing which was placed in the courtyard of the Laboratory of the Faculty of Engineering, Mechanical Engineering Study Program, Muhammadiyah University of Pontianak, with a testing time of ± 10 times the test.

3.2. Method

The method used in this study is the design of a saltwater desalination tool for the solar still system, which includes analysis of the yield of fresh water produced using a single basin desalination that was previously designed by previous researchers using fins, sponges, and axes to increase productivity[36]. In this study, the researchers developed a desalination system by utilizing solar energy and supporting it with heat storage material techniques, or what is often known as PCM (phase change material), so that

the temperature of the tool will not drop quickly and it will continue to produce fresh water not only during the day but also in the afternoon and evening when the intensity of the sun begins to decrease.



(a)



(b)

Fig.1 PCM wrapped using stainless steel balls

The PCM used in this study was "paraffin wax," with a melting point of around 49–53 °C. It had a mass of 1,720 g, which was divided into 10 balls, each of which had a mass of 172 g. As for the type of ball used to wrap paraffin wax, it is a stainless steel ball with a thickness of 1 mm and a ball size of 3 inches. In the process of designing the tool, the writer is assisted by software that is accessed on a laptop, while the software used in the design process of the desalination tool is Autodesk Inventor, which is able

to imitate the original form that will be made in the real world.

3.3. Test Equipment Design

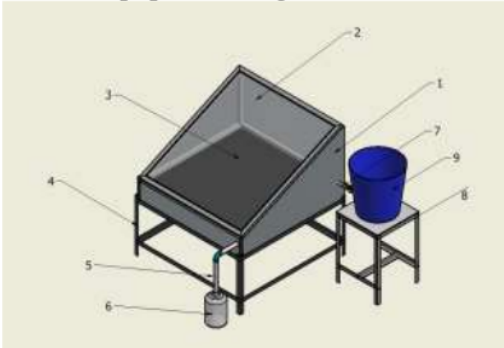

Fig.2 Seawater desalination plant design

Caption:

1. Evaporators
2. transparent glass
3. salt water tank
4. evaporator table
5. fresh water outlet pipe from the condensation process
6. fresh water storage tank
7. saltwater inlet
8. saltwater tank table
9. saltwater tank

3.3.1. Evaporator Frame

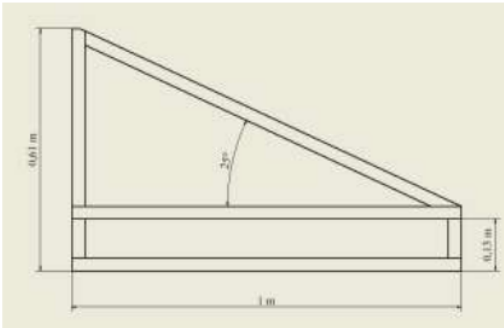

Fig.3 Side view of evaporator frame

The evaporator frame is made with a slope angle of 25°, disrupting previous research.

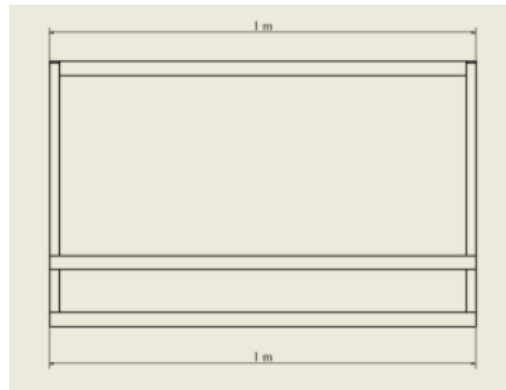

Fig.4 Rear view of the evaporator frame

3.4. Working Principle of Desalination Equipment

The working principle of the desalination device is by heating salt water or sea water with solar thermal energy until the water temperature increases so that an evaporation process occurs or what is often known as the evaporation process, after the subsequent evaporation process there will be a condensation event or condensation process where this process changes vapor or gas becomes liquid, as a result of this incident the collected water droplets attached to the top cover glass will then flow to the end of the gutter which is located under the glass, then the water that has dripped into the gutter will flow into the fresh water tank.

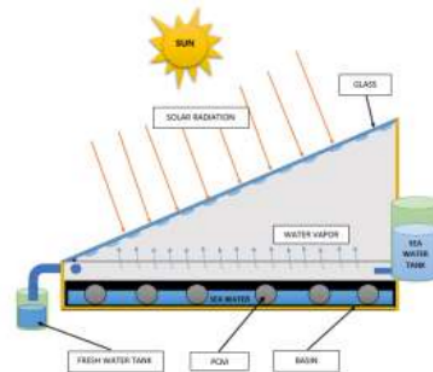

Fig.5 solar still system with additional PCM

In this study, a thermocouple was used to collect data on the temperature of the desalination device. The temperature measurements that will be taken include the temperature of the outside environment, the temperature in the evaporator, the temperature of the water in the basin, and the temperature of the glass.

4 Results and Discussion



Fig.6 Seawater desalination equipment

Based on the design results of the solar desalination device, in this study a desalination device was built and assembled as shown in Figure 6 above, which is the result of the assembly of several components involved in the manufacture of a solar desalination device. In making this solar desalination device, the first thing to do is to make the evaporator chamber, which consists of several components such as the evaporator frame, the dimensions of which are shown in Figures 3 and 4, and which are made of hollow aluminum measuring 22 cm x 34 cm with a thickness of 1 mm. plain zinc with a thickness of 0.2 mm, after the evaporator is finished, the next stage is to make a saltwater reservoir inside the evaporator with a height of 0.07 m, a length of 0.95 m, and a width of 0.92 m, which was made using plywood with a thickness of 8 mm coated with resin and painted black. Then the next step is to make the cover frame for the evaporator with a length of 1.08 m and a width of 1 m, which is given plain glass as a medium for the condensation process to occur. After all the components have been made, the next step is to unite them into a complete tool.

Table 1 the specification of the glass used in the manufacture of the top cover of the apparatus

No	Information	
1	type	Transparent glass
2	Thickness	3mm
3	long	1012 cm
4	wide	934 cm
5	Thermal conductivity	1.05W/m2K



(a)



(b)



(c)

Fig.7 Desalination equipment components

The pictures above are a series of components that have been made into original objects that were previously designed using the Autodesk Inventor software. After all the components are made and assembled, the next step is to carry out a series of experimental tests on the solar desalination system tool to determine the production of distillate water (fresh water from the desalination tool) in the tool with a water depth in a 3 mm saltwater bath and different treatment from the tool where the first is

without PCM and the second is using PCM. The results of the tests were carried out for 1 week. The data were taken six times with different treatments applied to the device, the first without PCM and the second using PCM with a water depth of 3 cm, and the results presented are the average results of each treatment, three times without PCM and three times using PCM

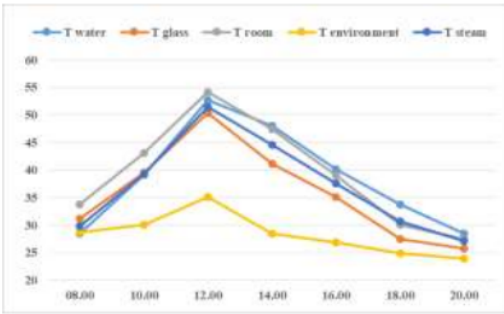

Fig.8 Comparison of temperature versus time from the average of 3 experiments without PCM

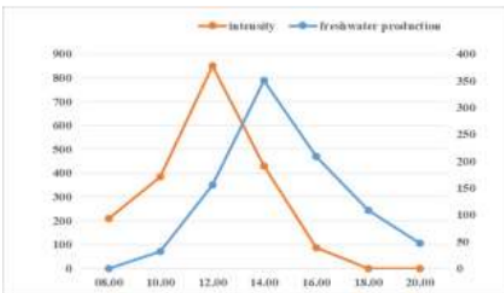

Fig.9 Comparison of solar radiation intensity with freshwater productivity from an average of 3 trials without PCM

Seen in figure 9 is a graph comparing the intensity of solar radiation with fresh water productivity from an average of 3 trial without PCM, you can see the numbers on the graph show that the highest intensity occurs at 12.00 and the lowest intensity at 18.00-20.00 because it is night, we can see that at 14.00 the sun's intensity dropped dramatically this was due to a change in weather which at first was sunny suddenly turned into rain, so that it can affect the temperature in the evaporator, with drastic changes in temperature this can effect the fast and slow condensation process due to changes in temperature that occur in the evaporator cover and the environment. With the decrease in temperature and intensity of solar radiation, it can have an impact on the condensation process to speed up so that the amount of fresh water that occurs at 12.00 when the

high temperature changes to low at 14.00, the water produced will increase, but this impact only occurs from 12.00 to 14.00 where the temperature that occurs in the tool will experience a drastic temperature drop so that the yield of fresh water will decrease drastically along with decreasing intensity, temperature in the tool and the environment. Therefore it can be concluded that the size of the intensity of the sun can affect the amount of fresh water productivity and temperature in the tool.

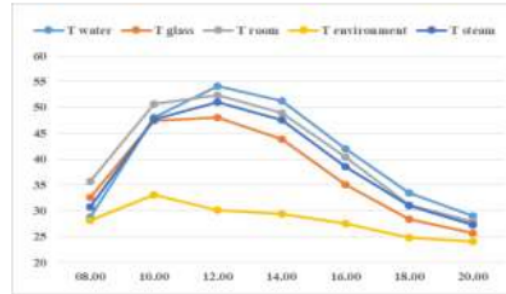

Fig.10 Comparison of temperature versus time from the average of 3 experiments using PCM

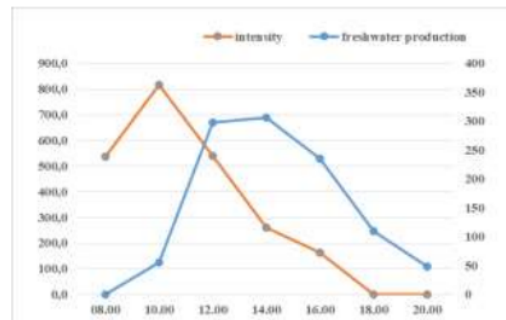

Fig.11 Comparison of solar radiation intensity with freshwater productivity from an average of 3 trials using PCM

As seen in Figure 10, which shows an increase and decrease in temperature in water, glass, room, environment, and steam, the highest average temperature in the tool occurs at 12.00 and the lowest at night at 20.00. The graph shows a decrease in temperature that occurs from 12.00 to 20.00 this happens due to change in the intensity of sunlight weather conditions, can be seen in graph 11 for the intensity of sunlight at 12.00 to 14.00 experienced a drastic decrease due to change the weather that was initially sunny became rainy, these conditions can have an impact on decreasing the temperature of the tool, but the decrease that occurs does not experience a drastic decrease compared to tools without PCM, this happens because of the PCM which releases heat

that has previously been absorbed when the temperature in high water reaches its melting point, after the temperature on the device has decreased below the melting point of the PCM at that time the PCM releases heat that has previously been absorbed so that the temperature at the tool can be kept from experiencing a drastic decrease, but it all depends again on the weather that occurs, if the weather changes from hot sunny suddenly to rain, it is possible that the temperature on the tool will experience a drastic decrease both using PCM and without PCM.

As seen in Figure 11, which is a graph of the comparison of solar radiation intensity with freshwater productivity from an average of 3 experiments using PCM, it can be seen on the graph that the highest intensity is at 10.00 and the lowest intensity is at 18.00–20.00 at night. Judging from the graph, there is a drastic decrease in the intensity of solar radiation at 14.00 even though it is still during the day due to a change in weather that was initially bright and suddenly rained; this will have an impact on the fast and slow processes of condensation and the amount of fresh water produced. We can see in a graph that the intensity of solar radiation at 10.00 is the greatest intensity, and at 12.00 the intensity has decreased but is still in the average intensity at the beginning of the hour; however, with a change in intensity that initially decreases, this can also have an impact on the temperature and productivity of fresh water. for the intensity at 14.00 was a drastic

decrease. At that time, the weather experienced a change where the initially sunny weather turned cloudy and suddenly rained, which had an impact on decreasing the temperature on the equipment and the environment, but this made water productivity increase due to changes in temperature that occurred on the glass, which made the condensation process fast. The decrease in the intensity of the sun affects the temperature of the equipment so that the evaporation process decreases and the steam produced decreases due to reduced heat.

With the difference in intensity and temperature that occurs, the conduction Q rate that occurs on the evaporator cover glass will also be different during the test time so that this can affect the productivity of fresh water.

To find the conduction Q on the glass can be found using equation (3):

$$Q = -k.A.\left(\frac{dT}{dx}\right)$$

$$Q = -k.A.\left(\frac{K_2 \times K_1}{L}\right)$$

Where:

- Q = heat transfer rate
- k = thermal conductivity of glass
- K1 = glass temperature
- K2 = ambient temperature
- L = thick glass

Table 2 Comparison of temperature against time without PCM

no	time	T water	T glass	T room	T vapor	T environment	intensity	distilate
1	08.00	31,2	31,2	33,7	29,9	28,7	210,5	0
2	10.00	39,1	39,5	43,1	39,3	30,1	383,8	32
3	12.00	52,7	50,3	54,2	51,5	35,1	850,6	156
4	14.00	48	41,1	47,4	44,6	28,4	429,9	351
5	16.00	40,1	35,1	39	37,6	26,9	86,6	209
6	18.00	33,7	27,5	30	30,6	24,9	0	109
7	20.00	28,4	25,7	27,4	27,1	23,9	0	47

Table 3 Comparison of temperature against time using PCM

no	time	T water	T glass	T room	T vapor	T environment	intensity	distilate
1	08.00	28,8	32,6	35,7	30,7	28,1	536,9	0
2	10.00	48	47,4	50,6	47,7	33,1	818,0	55
3	12.00	54,1	48	52,4	51,1	30,1	541,0	298
4	14.00	51,3	43,8	48,9	47,6	29,3	261,5	306
5	16.00	42	35	40,4	38,5	27,5	163,6	235
6	18.00	33,5	28,4	31,1	31	24,8	0	110
7	20.00	29	25,6	27,9	27,3	24,1	0	48

Table 4 the ratio of the conduction Q of the glass to time

No	time	Q conduction in glass (W/m ² .K)	
		PCM No	Using PCM
1	08.00	82.5	148.5
2	10.00	310.2	471.9
3	12.00	501.6	590.7
4	14.00	419.1	478.5
5	16.00	270.6	247.5
6	18.00	85.8	118.8
7	20.00	59.4	49.5

We can see in the table for Q conduction on glass with tool treatment without PCM that the largest number occurred at 12.00 at 501.6 W/m².K and the lowest figure occurred at 20.00 at 59.4 W/m².K because it is night. Whereas for Q conduction on glass with tool treatment using PCM, the highest number occurred at 12.00 at 590.7 W/m².K and the lowest figure occurred at 20.00 at 49.5 W/m².K because it was at night.

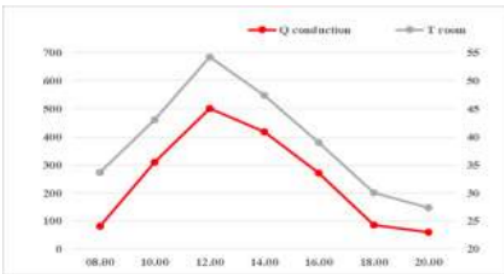

Fig.12 Comparison of glass conduction Q rate with T room versus time without PCM

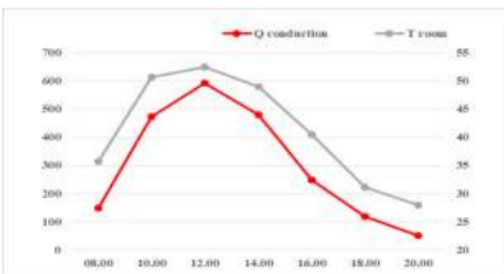

Fig.13 Comparison of glass conduction Q rate with T room versus time using PCM

Figures 12 and 13 show a comparison of the conduction Q rate of the glass with the temperature in the evaporation chamber which is given different treatment on the device where one is without PCM and the other is given additional PCM, we can see that the graph shows a change in room temperature as the temperature changes the Q rate of conduction on

the glass, the greater the Q rate of conduction, the temperature of the evaporator space will also increase, and vice versa the smaller the Q rate of conduction on the glass, the temperature in the evaporator chamber will also decrease, as for the factors that cause differences in the Q rate of conduction on glass and The temperature of the evaporator room over time can occur due to changes in weather and the intensity of sunlight received.

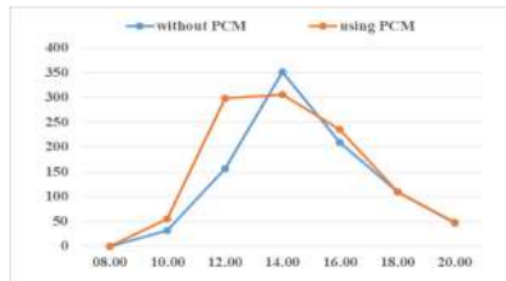

Fig.14 Comparison of freshwater productivity without PCM and using PCM against time



Fig.15 Comparison of the average amount of fresh water produced from 3 experiments without PCM and 3 experiments using PCM

From Figure 14, we can see that the highest amount of fresh water yield occurred at 14.00, both without PCM and using PCM. It can be seen in the graph that the yield of fresh water without PCM experienced a significant increase at 14.00 compared to using PCM. and when the environmental temperature and the intensity of sunlight fall, the amount of water produced drops drastically while the tool is treated using PCM. If the environmental temperature and sunlight intensity drop, the amount of water produced will also decrease, but not drastically. This is due to the working PCM, which functions to store heat so that it is possible to keep the temperature from dropping drastically. And we can also see that the average production of water produced by those without PCM is lower than that of those using PCM.



Fig.16 Comparison of desalination equipment efficiency without PCM and using PCM

Based on Figure 16, it can be seen that the efficiency of testing the tool without PCM reached 19.4%, with an average fresh water productivity of 904 ml, while the efficiency of the equipment using PCM reaches 24.5%, with an average fresh water productivity of 1052 ml.

5 Conclusion

Design and manufacture of a laboratory-scale solar still system seawater desalination device with the addition of PCM (Phase Change Material) as a heat storage material which will then be tested to determine the productivity of the tool that has been made, from a series of tests carried out from 08.00 to with 20.00 as a whole the solar still system desalination device is running well, for the yield of fresh water produced in the tool without PCM treatment it produces less water compared to the tool treated with the addition of PCM, and for the temperatures in the tool without the addition of PCM treatment the temperature has decreased drastically compared to the tool that was treated by adding PCM as a heat storage material so that the temperature in the tool does not drop drastically. this proves that there is heat stored in the PCM so that the temperature drop does not drop drastically, as for factors that can affect the performance of the tool, including the intensity of the existing sunlight, the size of the intensity received by the tool can affect the temperatures of the tool, if the intensity of the sun is high, the temperature of the device will also be high, and vice versa, if the intensity of the sun is low, the temperature will also decrease, both the temperature inside the device and the ambient temperature.

Reference:

- [1] A. W. Pratama, J. Nurdiana, and I. Meicahayanti, "PENGARUH PERBEDAAN JENIS PLAT PENYERAP KACA DAN

PAPAN MIKA TERHADAP KUALITAS DAN KUANTITAS AIR MINUM PADA PROSES DESTILASI ENERGI TENAGA SURYA," no. November, pp. 35–40, 2017.

- [2] A. H. dan N. I. Said and Kelompok, "APLIKASI TEKNOLOGI PENGOLAHAN AIR SEDERHANA UNTUK MASYARAKAT PEDESAAN Oleh," vol. 1, no. 2, 2005.
- [3] H. M. Qiblawey and F. Banat, "Solar thermal desalination technologies," vol. 220, pp. 633–644, 2008, doi: 10.1016/j.desal.2007.01.059.
- [4] H. Mahmoudi, N. Spahis, M. F. Goosen, N. Ghaffour, N. Drouiche, and A. Ouagued, "Application of geothermal energy for heating and fresh water production in a brackish water greenhouse desalination unit: A case study from Algeria," vol. 14, pp. 512–517, 2010, doi: 10.1016/j.rser.2009.07.038.
- [5] A. J. dan M. A. Widi Astuti, "DESALINASI AIR PAYAU MENGGUNAKAN SURFACTANT MODIFIED ZEOLITE (SMZ)," no. August 2015, 2006.
- [6] A. Bhattacharyya, "Solar Stills for Desalination of Water in Rural Households," vol. 2, no. 1, pp. 21–30, 2013.
- [7] M. N. Alfian Putra, Ridwan, "RANCANG BANGUN ALAT PENJERNIHAN AIR GAMBUT MENJADI AIR BERSIH Alfian."
- [8] JOEL PHANTER NABABAN, "Rancang bangun alat desalinasi air laut tenaga surya sistem pasif kemiringan ganda dengan air sebagai pendingin kaca luar," 2019.
- [9] P. Taylor, M. T. Chaichan, K. I. Abaas, and H. A. Kazem, "Design and assessment of solar concentrator distilling system using phase change materials (PCM) suitable for desertic weathers," no. July, 2015, doi: 10.1080/19443994.2015.1069221.
- [10] F. C. Nababan and H. Ambarita, "Rancang Bangun Alat Desalinasi Air Laut Sistem Vakum Natural dengan Media Evaporator dan Kondensor yang dimodifikasi Flange," *Cylind. J. Ilm. Tek. Mesin*, vol. 3, no. 1, pp. 16–25, 2017.
- [11] N. Ghaffour, J. Bundschuh, H. Mahmoudi, and M. F. A. Goosen, "Renewable energy-driven desalination technologies: A comprehensive review on challenges and potential applications of integrated systems," *DES*, 2014, doi: 10.1016/j.desal.2014.10.024.
- [12] M. A. Eltawil and Z. Zhengming, "Wind turbine-inclined still collector integration with solar still for brackish water desalination," *DES*, vol. 249, no. 2, pp. 490–

- 497, 2009, doi: 10.1016/j.desal.2008.06.029.
- [13] Z. Haddad, A. Chaker, and A. Rahmani, "Improving the basin type solar still performances using a vertical rotating wick," *Desalination*, vol. 418, pp. 71–78, 2017, doi: 10.1016/j.desal.2017.05.030.
- [14] H. Ambarita, "Rancang Bangun Alat Desalinasi Air Laut Sistem Vakum Alami Dengan Tenaga Surya," *J. Flywheel*, vol. 9, no. 1, pp. 37–42, 2018, [Online]. Available: <https://ejournal.itn.ac.id/index.php/flywheel/article/view/2558>.
- [15] D. Zhang, S. Tian, and D. Xiao, "Experimental study on the phase change behavior of phase change material confined in pores," *Sol. Energy*, vol. 81, no. 5, pp. 653–660, 2007, doi: 10.1016/j.solener.2006.08.010.
- [16] A. Sharma, V. V Tyagi, C. R. Chen, and D. Buddhi, "Review on thermal energy storage with phase change materials and applications," vol. 13, pp. 318–345, 2009, doi: 10.1016/j.rser.2007.10.005.
- [17] J. Firmansyah, "Eksplanasi Ilmiah Air Mendidih Dalam Suhu Ruang," *J. Filsafat Indones.*, vol. 1, no. 2, p. 75, 2018, doi: 10.23887/jfi.v1i2.13993.
- [18] D. Mardiansyah, A. Fatoni, and Y. Febriani, "Pkm Revitalisasi Sistem Penyediaan Air Rawa Menjadi Air Bersih Layak Konsumsi Di Desa Langkitin Dengan Menggunakan Teknologi Tepat Guna," *BERNAS J. Pengabd. Kpd. Masy.*, vol. 2, no. 1, pp. 14–19, 2021, doi: 10.31949/jb.v2i1.563.
- [19] M. Syahri, "Rancang Bangun Sistem Desalinasi Energi Surya Menggunakan Absorber Bentuk Separo Elip Melintang," *Pros. Semin. Tek. Kim. Kejuangan*, 2011.
- [20] H. Mahmoudi *et al.*, "Assessment of wind energy to power solar brackish water greenhouse desalination units: A case study from Algeria," vol. 13, pp. 2149–2155, 2009, doi: 10.1016/j.rser.2009.03.001.
- [21] R. A. Koestoer, "Characteristic Testing of Solar Still X Desalination Technology in Indonesia using Seawater," *Pros. SNTTM XVII*, pp. 069–077, 2018, [Online]. Available: <http://prosiding.bkstm.org/prosiding/2018/K-E-12.pdf>.
- [22] H. Ambarita *et al.*, "RANCANG BANGUN ALAT DESALINASI AIR LAUT TENAGA SURYA SISTEM PASIF KEMIRINGAN GANDA DENGAN AIR SEBAGAI PENDINGIN KACA LUAR," no. 2, pp. 9–19, 2019.
- [23] A. Wijaya, "Rancang bangun sistem distilasi air dalam proses pengolahan air bersih dengan menggunakan," *Magister Sci.*, no. 40, pp. 71–83, 2016.
- [24] A. E. Kabeel, M. Abdelgaied, and M. Mahgoub, "The performance of a modified solar still using hot air injection and PCM," *Desalination*, vol. 379, pp. 102–107, Feb. 2016, doi: 10.1016/j.desal.2015.11.007.
- [25] A. Sandeep, S. K. B, and V. K. D. C, "Experimental study on modified single slope single basin active solar still," *Desalination*, vol. 367, pp. 69–75, 2015, doi: 10.1016/j.desal.2015.03.031.
- [26] T. Kusumah, T. Wahyudi, and M. Widodo, "PHASE CHANGE MATERIAL DARI CAMPURAN PARAFIN UNTUK TEKSTIL SWA-TERMOREGULASI PHASE CHANGE MATERIAL FROM BINARY MIX PARAFFINS FOR SELF-THERMOREGULATING TEXTILES." [27] M. N. A. Hawlader, M. S. Uddin, and M. Mya, "Microencapsulated PCM thermal-energy storage system," vol. 74, pp. 195–202, 2003.
- [28] R. Baetens, B. P. Jelle, and A. Gustavsen, "Phase change materials for building applications: A state-of-the-art review," *Energy Build.*, vol. 42, no. 9, pp. 1361–1368, 2010, doi: 10.1016/j.enbuild.2010.03.026.
- [29] W. Pudjiastuti, "Jenis-Jenis Bahan Berubah Fasa dan Aplikasinya," *J. Kim. dan Kemasan*, vol. 33, no. 1, p. 118, 2011, doi: 10.24817/jkk.v33i1.1838.
- [30] I. G. Y. Dewantara, B. M. Suyitno, and I. G. E. Lesmana, "Desalinasi Air Laut Berbasis Energi Surya Sebagai Alternatif Penyediaan Air Bersih," vol. 07, no. 1, pp. 3–6, 2018.
- [31] rahayu deny danar dan alvi furwanti Alwie, A. B. Prasetio, R. Andespa, P. N. Lhokseumawe, and K. Pengantar, "ANALISA LAJU PERPINDAHAN PANAS KOLEKTOR SURYA TIPE PLAT DATAR PADA ALAT DESALINASI AIR LAUT," *J. Ekon. Vol. 18, Nomor 1 Maret 201*, vol. 2, no. 1, pp. 41–49, 2020.
- [32] T. Wiradhani, "Rancang Bangun Pemanas Air Tenaga Surya Dengan Menggunakan Kolektor Surya Plat Datar," *Tugas Akhir-Tm 090340*, pp. 1–85, 2012.
- [33] V. Kumar, J. Prasad, and A. Sarkar, "Solar distillation using three different phase change materials stored in a copper cylinder," *Energy Reports*, vol. 5, pp. 1532–1542, 2019, doi: 10.1016/j.egyr.2019.10.023.

- [34] E. T. Saputra, N. K. Caturwati, and I. Rosyadi, "PENGARUH MASSA PHASE CHANGE MATERIAL (PCM) TERHADAP PRODUKTIVITAS DAN EFISIENSI ALAT DESTILASI TENAGA SURYA MENGGUNAKAN PCM JENIS LAURIC ACID SEBAGAI PENYIMPAN PANAS," 2021.
- [35] K. Astawa, M. Sucipta, I. P. Gede, and A. Negara, "Analisa Performansi Destilasi Air Laut Tenaga Surya Menggunakan Penyerap Radiasi Surya Tipe Bergelombang Berbahan Dasar Beton," *J. Energi Dan Manufaktur*, vol. 5, no. 1, pp. 7–13, 2012.
- [36] P. Durkaieswaran and K. K. Murugavel, "Various special designs of single basin passive solar still - A review," *Renew. Sustain. Energy Rev.*, vol. 49, pp. 1048–1060, 2015, doi: 10.1016/j.rser.2015.04.111.

Design of a Seawater Desalination Device for Laboratory Scale Solar Still Systems with the Addition of PCM (Phase Change Material) as a Heat Storage Material

ORIGINALITY REPORT

15%

SIMILARITY INDEX

10%

INTERNET SOURCES

9%

PUBLICATIONS

4%

STUDENT PAPERS

MATCH ALL SOURCES (ONLY SELECTED SOURCE PRINTED)

2%

★ hdl.handle.net

Internet Source

Exclude quotes On

Exclude matches < 5 words

Exclude bibliography On